



## PR 6241 Compression S-Type Load Cell



100 kg... 5 t, type D1 | C3 | C6

- Easy to install
- Easy corner adjustment by matched load cell outputs
- Full stainless steel construction
- Wide temperature range
- Resistant against vibration
- Hermetically sealed, IP68, IP69K (depth of 1.5 m for 10,000 hrs.)
- Ex-version available
- W&M approval (According to OIML R60)

### Product Profile

The PR 6241 range of load cells is specially designed for weighing small and medium-sized process vessels and for high-precision dosing. The unique design principle, in combination with the FlexLock-mounting kits, makes it possible to counterbalance movements arising from mechanical or thermal expansion or contraction of the vessel or its supporting construction.

The load cell is manufactured entirely from stainless steel. A particular design characteristic is the combination of "genuine" shear force and pendulum support principles, which make for unrivalled accuracy.

At the same time, this range distinguishes itself – in addition to its high measurement accuracy and repeatability – above all for its unmatched reliability, robustness and stability, which enable trouble-free operation without adjustment, year after year. With the associated installation kit, the pendulum support principle ensures that force transmission into the sensor is always at the optimum level and, in this way, the effect on measurement accuracy is minimized, whilst high repeatability and perfect linearity are maintained.

There is a particularly wide working temperature range attributable to special resistance strain gauge technology. The hermetically sealed enclosure and special TPE cable allow the unit to be used even under extreme operating conditions in harsh production environments. The entire measurement chain can be calibrated without the use of a reference weight. Due to "matched output" technology, a damaged load cell can be exchanged without the need for re-calibration. This saves a tremendous amount of time during commissioning. An explosion-proof (Ex) version of this range of load cells is also available, as an option, for use in intrinsically safe environments.

**Load cell construction**

S-shape design with integrated load return.  
Full stainless steel construction, hermetically sealed, welded, filled with inert gas.

**Material**

Load cell: 1.4542 (DIN 17440) similar to S604, S622 (B.S.), 17 - 4PH

**Protection**

IP68, IEC 529 (equivalent to NEMA 6).  
The load cell can be submerged in water to a depth of 1.5 m for 10,000 hours.

**Cable**

Robust, flexible, screened  
Sheath: TPE Thermopl. Elastomere,  
Colour: grey (EX: blue)  
Diameter: 5 mm, wires 4 × 0.35 mm<sup>2</sup>  
Length: 5 m

**Bending radius**

Fixed installation: ≥ 50 mm  
Flexible installation: ≥ 150 mm

**Certificate of conformity PR 6241/..E**

Feature:  
II 1G EEx ia IIC T6, II 1D IP65 85 °C  
Registration number:  
PTB 02 ATEX 2059, TÜV 03 ATEX 2301x

Technical Data			D1	C3	C6	
Accuracy class			0.04	0.015	0.008	% E <sub>max</sub>
Minimum dead load	lowest limit of specified measuring range	E <sub>min</sub>	0	0	0	% E <sub>max</sub>
Maximum capacity	highest limit of specified measuring range	E <sub>max</sub>	s.table	s.table	s.table	
Max. usable load	upper limit for measurements	E <sub>u</sub>	150	150	150	% E <sub>max</sub>
Destructive load	danger of mechanical destruction	E <sub>d</sub>	> 300	> 300	> 300	% E <sub>max</sub>
Min. LC verification interval	minimum load cell verification interval, (v <sub>min</sub> =E <sub>max</sub> /Y)	Y	5,000	14,000	20,000	
Deadload output return	actor for dead load output return after load (DR=1/2*E <sub>max</sub> /Z)	Z	1,000	3,000	8,000	
Rated output	relative output at nominal load	C <sub>n</sub>	2	2	2	mV/V
Tolerance on rated output	permissible deviation from rated output	d <sub>c</sub>	< 0.25	< 0.07	< 0.07	% C <sub>n</sub>
Zero output signal	load cell output signal under unloaded condition	S <sub>min</sub>	< 1.0	< 1.0	< 1.0	% C <sub>n</sub>
Repeatability error	max. change in load cell output for repeated loading	ε <sub>R</sub>	< 0.01	< 0.005	< 0.005	% C <sub>n</sub>
Creep, during 30 min.	max. change in load cell output under nominal load	d <sub>cr</sub>	< 0.03	< 0.015	< 0.008	% C <sub>n</sub>
Non - Linearity	max. deviation from best straight line through zero	d <sub>lin</sub>	< 0.03	< 0.01	< 0.01	% C <sub>n</sub>
Hysteresis	max. difference in load cell output when loading from zero to nominal load and unloading back to zero	d <sub>hy</sub>	< 0.04	< 0.015	< 0.008	% C <sub>n</sub>
Temperature effect on S <sub>min</sub>	max. change of S <sub>min</sub> /10 K DT over B <sub>T</sub> referred to C <sub>n</sub>	TK <sub>Smin</sub>	< 0.028	< 0.01	< 0.007	% C <sub>n</sub> /10 K
Temperature effect on C	max. change of C/10 K DT over BT referred to C <sub>n</sub>	TK <sub>c</sub>	< 0.03	< 0.01	< 0.005	% C <sub>n</sub> /10 K
Input impedance	between supply terminals	R <sub>LC</sub>	650 ± 6	650 ± 6	650 ± 6	Ω
Output impedance	between measuring terminals	R <sub>o</sub>	610 ± 1	610 ± 0.5	610 ± 0.5	Ω
Insulation impedance	between measuring circuit and housing 100 V <sub>DC</sub>	R <sub>IS</sub>	> 5,000	> 5,000	> 5,000	> 5,000 × 10 <sup>6</sup> Ω
Recommended supply voltage	to hold the specified performance	B <sub>u</sub>	4... 24	4... 24	4... 24	V
Insulation voltage	between circuit and housing, PR 6241/..E only		500	500	500	V
Max. supply voltage	permissible for continuous operation without damage	U <sub>max</sub>	25	25	25	V
Nominal ambient temp. range	to hold the specified performance	B <sub>T</sub>	-10... +55	-10... +55	-10... +55	°C
Usable ambient temp. range	permissible for continuous operation without damage	B <sub>Tu</sub>	-40... +95	-40... +95	- 40... +95	°C
Storage temperature range	Transportation and storage	B <sub>Tl</sub>	-40... +95	-40... +95	-40... +95	°C
Permissible eccentricity	permissible displacement from nominal load line	S <sub>ex</sub>	5	5	5	mm
Vibration resistance	resistance against oscillation (IEC 68-2-6 Fc)	-	20 g, 100 h, 10... 150 Hz	20 g, 100 h, 10... 150 Hz	20 g, 100 h, 10... 150 Hz	
Air pressure effects	influence of ambient air pressure on S <sub>min</sub>	PK <sub>Smin</sub>	0.005	0.0025	0.0025	% C <sub>n</sub> /kPa
Nominal deflection	max. elastic deformation under nominal load	S <sub>nom</sub>	< 0.5	< 0.5	< 0.3	mm

Definitions acc. to VDI/VDE 2637

The technical data given here serve only as a product description and must not be interpreted as guaranteed characteristics in the legal sense.

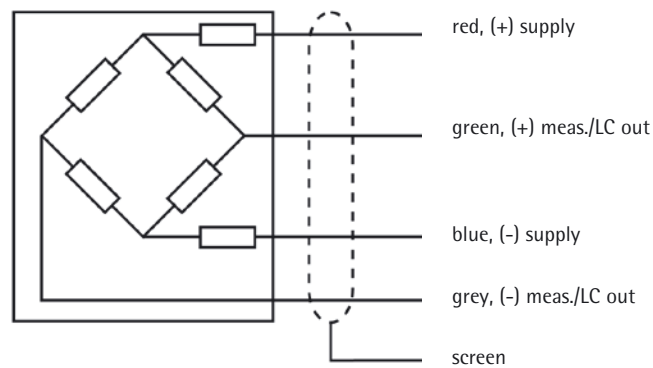
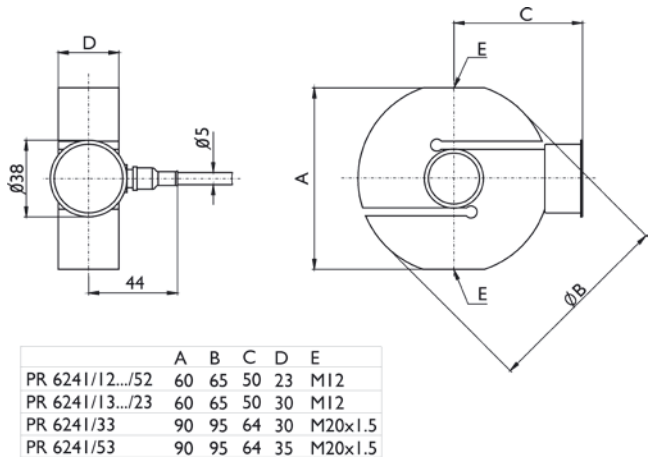

Dimensions in mm

### Order information

Type	Nominal Load $E_{max}$	Version	Ex-Version	Packing	Weight gross   net
PR 6241/12..	100 kg	/..D1	/..D1E	220 × 215 × 135 mm	1.2 kg   0.8 kg
PR 6241/22..	200 kg	/..D1/..C3/..C6	/..D1E/..C3E/C6E	220 × 215 × 135 mm	1.2 kg   0.8 kg
PR 6241/32..	300 kg	/..D1/..C3/..C6	/..D1E/..C3E/C6E	220 × 215 × 135 mm	1.2 kg   0.8 kg
PR 6241/52..	500 kg	/..D1/..C3/..C6	/..D1E/..C3E/C6E	220 × 215 × 135 mm	1.2 kg   0.8 kg
PR 6241/13..	1 t	/..D1/..C3/..C6	/..D1E/..C3E/C6E	220 × 215 × 135 mm	1.2 kg   0.9 kg
PR 6241/23..	2 t	/..D1/..C3/..C6	/..D1E/..C3E/C6E	220 × 215 × 135 mm	1.2 kg   0.9 kg
PR 6241/33..	3 t	/..D1/..C3/..C6	/..D1E/..C3E/C6E	220 × 215 × 135 mm	2.0 kg   1.7 kg
PR 6241/53	5 t	/..D1/..C3	/..D1E/..C3E	220 × 215 × 135 mm	2.2 kg   1.9 kg

Type	Further options		Dimensions	Order Number
PR 6130/08	Plastic cable junction box	for all industrial applications, max. 8 load cells	200 × 120 × 75 mm	9405 361 30081
PR 6130/04N	Cable junction box	Aluminium, grey painted, IP67, for all industrial applications, max. 4 load cells	175 × 80 × 57 mm	9405 361 30041
PR 6130/64Sa	Stainless steel cable junction box	material stainless steel 1.4301, IP68, IP69K, for all cable junction box industrial applications, intrinsically safe and W&M applications, max. 4 load cells	190 × 160 × 60 mm	9405 361 30642
PR 6130/65S	Stainless steel cable junction box	material stainless steel 1.4301, IP68, IP69K, for all cable junction box industrial applications, intrinsically safe and W&M applications, max. 4 load cells	172 × 105 × 55 mm	9405 361 30652
PR 6130/68S	Stainless steel cable junction box	material stainless steel 1.4404, IP68, IP69K, for all cable junction box industrial applications, intrinsically safe and W&M applications, max. 8 load cells	240 × 170 × 70 mm	9405 361 30682
PR 6135	Extension cable	for all applications	D = 9 mm	9405 361 35..2
PR 6135/..A	Extension cable, armoured	for all applications, grey	D = 13 mm	9405 361 35..9
PR 6136	Extension cable	for intrinsically safe applications, blue	D = 11 mm	9405 361 36..2
PR 6136/..A	Extension cable, armoured	for intrinsically safe applications, blue	D = 13 mm	9405 361 36..9
PR 6041/51S	Stainless steel platform foot	material 1.4542, special mounting solution for platform	(100 kg... 2 t load cells)	9405 360 41512
PR 6041/30N	Plate mounting kit	mild steel, zinc plated, without constraining	(100 kg... 2 t load cells)	9405 360 41301
PR 6041/30S	Stainless steel plate mounting kit	material 1.4301, stainless steel, without constraining	(100 kg... 2 t load cells)	9405 360 41302
PR 6041/40N	Plate mounting kit	mild steel, zinc plated, without constraining	(3 t, 5 t load cells)	9405 360 41401
PR 6041/40S	Stainless steel plate mounting kit	material 1.4301, without constraining	(3 t, 5 t load cells)	9405 360 41402
PR 6143/80N	Pivoting rod	up to 2 kN horizontal force, mild steel, zinc plated		9405 361 43801
PR 6143/83N	Pivoting rod	up to 20 kN horizontal force, mild steel, zinc plated		9405 361 43831
PR 6043/30N	MiniFlexlock	mounting kit, incl. constrainer up to 6 kN horiz. force	(100 kg... 2 t load cells)	9405 360 43301
PR 6043/30S	Stainless steel MiniFlexlock	material 1.4301, mounting kit, incl. constrainer up to 6 kN horiz. force	(100 kg... 2 t load cells)	9405 360 43302
PR 6043/31S	Stainless steel loadbutton set	material 1.4542, special load button set	(100 kg... 2 t load cells)	9405 360 43312
PR 6043/40N	MiniFlexlock	mounting kit, incl. constrainer up to 18 kN horiz. force	(3 t, 5 t load cells)	9405 360 43401
PR 6043/40S	Stainless steel MiniFlexlock	material 1.4301, mounting kit, incl. constrainer up to 18 kN horiz. force	(3 t, 5 t load cells)	9405 360 43402